



Ag5500

PoE Ultra Module

1. Features

- Maximum 60 Watt Output Power
- Small size (½ Brick)
- High efficiency DC/DC converter
- Wide adjustable output voltage range
- 1500V isolation (input to output)
- Input voltage range 52V to 57V (@ 60W)
- IEEE802.3af compliant inputs
- Low output ripple and noise
- Minimal (low cost) external components required
- Overload, thermal and short-circuit protection
- Silvertel “design-in” assistance

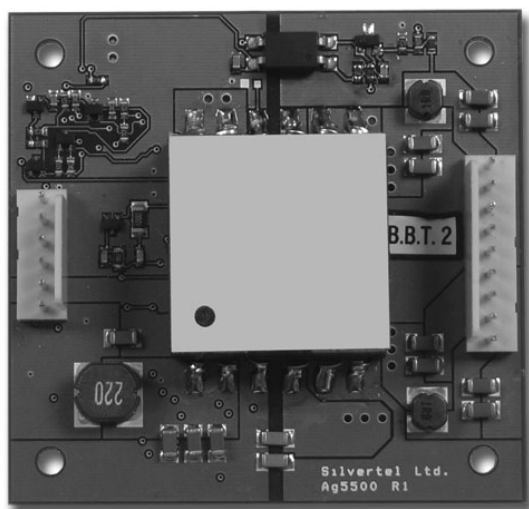

2. Description

The Ag5500 is a High Power over Ethernet (PoE Ultra) module that can deliver up to 60 Watts of output power. Suitable for applications such as WiMAX access points, PTZ cameras, notebook computers and thin client terminals.

The Ag5500 has been designed to extract power from Power Sourcing Equipment (PSE) over an Ethernet cable. The module's input conforms to the IEEE 802.3af standard for signature recognition and class programming. It has been designed to work with existing high power PSE's from leading manufacturers.

The high efficiency DC/DC converter operates over a wide input voltage range and provides a regulated low ripple and low noise output. The DC/DC converter also has built-in overload, thermal and short-circuit output protection.

Table of Contents

1. Features	1
2. Description.....	1
Table of Contents	2
Table of Figures	2
3. Ag5500 Product Selector.....	3
4. Pin Description	4
5. Functional Description	5
5.1 Inputs.....	5
5.2 PD Signature	5
5.3 Isolation	6
5.4 Power Classification	6
5.5 Input configuration	7
5.6 DC/DC Converter	7
5.7 Output Configuration	7
5.8 Output Adjustment.....	8
5.9 Output Power.....	9
5.10 Typical Connections	10
6. Operating Temperature Range.....	11
7. Protection	12
8. Connections.....	12
9. Electrical Characteristics	12
9.1 Absolute Maximum Ratings ¹	12
9.2 Recommended Operating Conditions.....	12
9.3 DC Electrical Characteristics	13
10. Package	14

Table of Figures

Figure 1: Block Diagram	3
Figure 2: Ag5500 Package Format	3
Figure 3: Typical System Diagram.....	5
Figure 4: Class Programming Option.....	6
Figure 5: Input Power configuration	7
Figure 6: Output Configurations	8
Figure 7: Output Adjustment.....	9
Figure 8: Typical Connection Diagram.....	10
Figure 9: Module Pin Isolation (bottom view).....	11
Figure 10: Suggested Heat Sink Assembly.....	11

3. Ag5500 Product Selector

Part Number†	Nominal Output Voltage ‡	Maximum Output Power *
Ag5500	12V / 24V	60W

*At 25°C must include adequate thermal management

† The Ag5500 fully meets the requirements of the RoHS directive 2002/95/EC on the restriction of hazardous substances in electronic equipment.

‡ Voltage depending on output configuration (Parallel or Series), see Section 5.7.

Table 1: Ordering Information

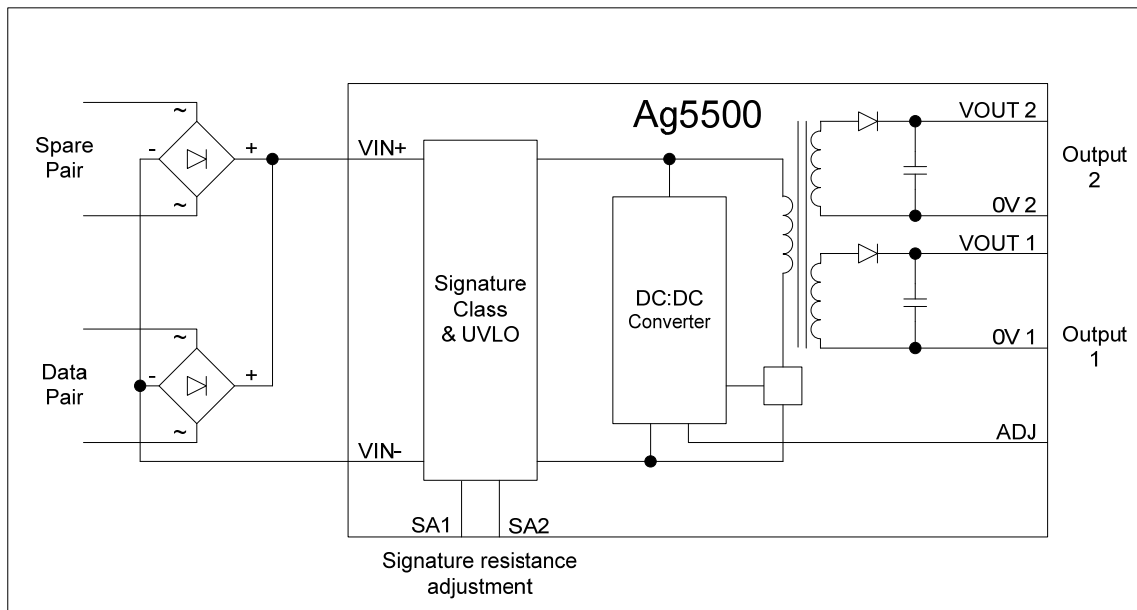

Figure 1: Block Diagram

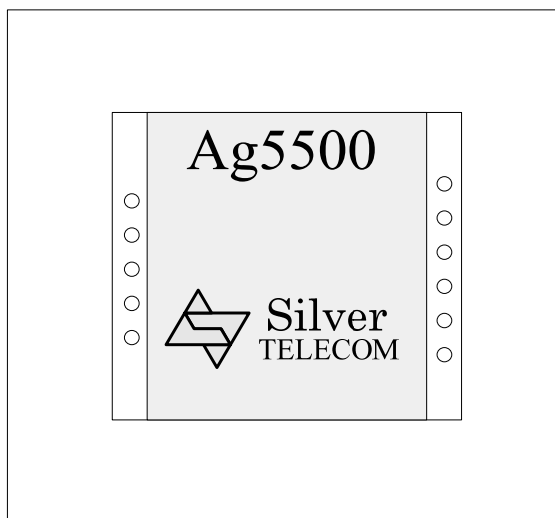

Figure 2: Ag5500 Package Format

4. Pin Description

Input Connector pins J1

Pin #	Name	Description
1	VIN+	Direct Input +. This pin connects to the positive (+) output of the input bridge rectifier.
2	VIN-	Direct Input -. This pin connects to the negative (-) output of the input bridge rectifier.
3	CPA	Class Programming. Connecting an external resistor from this pin to VA- will change the current class of this input. With no resistor fitted this input will default to Class 0.
4	NC	Reserved
5	SA1	Signature resistance adjustment
6	SA2	Signature resistance adjustment

Output Connector pins J2

Pin #	Name	Description
1 & 2	VOUT 1	DC Output. This pin provides the main regulated output from the DC/DC converter.
3 & 4	0V 1	Ground. The ground return for the VOUT 1 output.
5	ADJ	Output Adjust. The output voltage can be adjusted from its nominal value, by connecting an external resistor from this pin to either the VOUT 1 pin or the 0V 1 pin.
6 & 7	0V 2	Ground. The ground return for the VOUT 2 output.
8 & 9	VOUT 2	DC Output. This pin provides the secondary output from the DC/DC converter.

5. Functional Description

5.1 Inputs

The Ag5500 has a single input that can be connected to two external bridge rectifiers (see Figure 1: Block Diagram). This allows the Ag5500 to be compatible with equipment that uses the different power options, see Figure 5: Input Power Options. The Ag5500 was developed for and tested with the Phihong POE80U, POE60U and the PowerDsine 9501G.

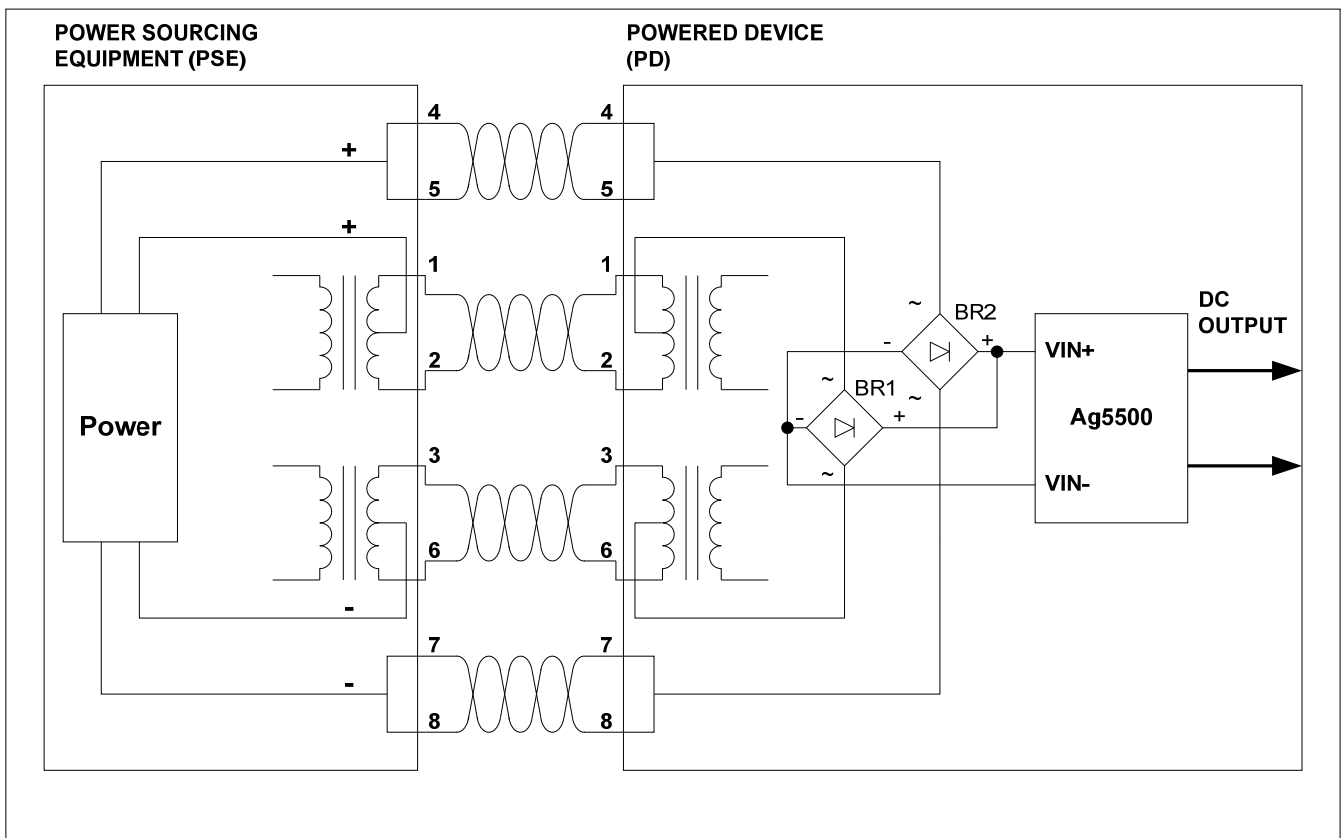

Figure 3: Typical System Diagram

5.2 PD Signature

The Ag5500 input complies with the IEEE802.3af specification. When the inputs are connected to a Power Sourcing Equipment (PSE), they will automatically present a Powered Device (PD) signature to the PSE (when requested). The equipment will then recognise that a PD is connected to that line and supply power.

The SA1 and SA2 pins must be connected together when used with a Phihong POE80U or POE60U PSE.

5.3 Isolation

To meet the isolation requirements of IEEE802.3af section 33.4.1 a Powered Device (PD) must pass the electrical strength test of IEC 60950 sub clause 6.2. This calls for either a) 1500VAC test or b) 1500V impulse test. The Ag5500 has been designed to meet b) 1500V impulse test. When mounting the module to the heat sink, you must ensure a clearance of 1.5mm minimum between the pins of the connectors and the heat sink or use some form of isolation such as at least two layers of 3M#56 insulating tape.

5.4 Power Classification

The Ag5500 input offers IEEE802.3af “Class Programming”. This is optional from the PSE and is used for power management. The Ag5500 allows the class current to be externally programmed by connecting a resistor (RC) between the CP and VIN- pins, see below. If no resistor is fitted the Ag5500 will default to Class 0. The Phihong POE80U, POE60U and the PowerDsine 9501G ignore power classification.

CLASS	Programming Resistance (Ohms)	PSE Power (W)
0	Do not fit	
1	698 ±1%	4
2	383 ±1%	7
3	249 ±1%	15.4
4	182 ±1%	30

Table 2: Class Programming

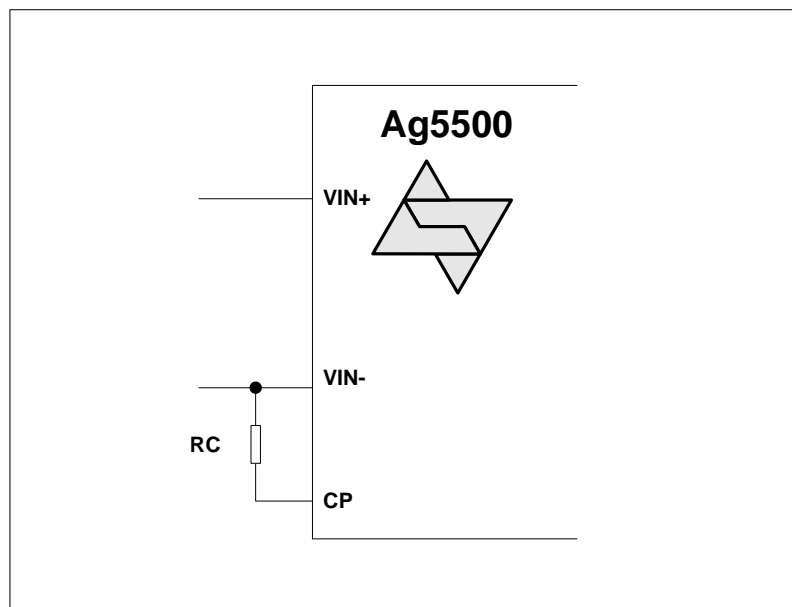

Figure 4: Class Programming Option

5.5 Input configuration

To get maximum power the Ag5500's must be configured to accept inputs from both the spare pair and data pair as shown in Figure 3: Typical System Diagram and Figure 5: Input Power Configuration.

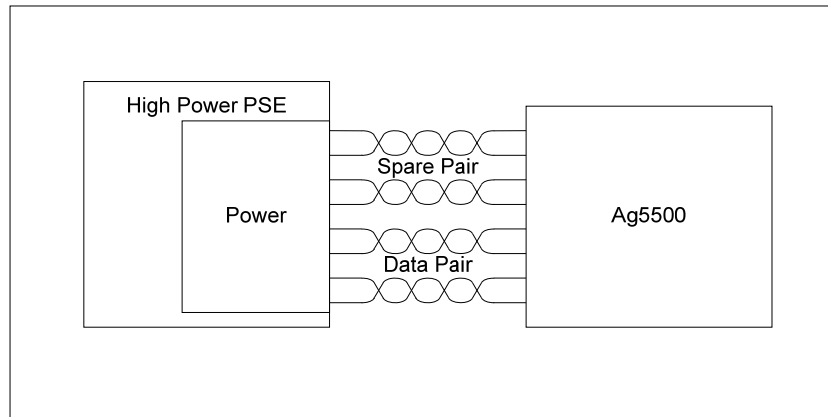

Figure 5: Input Power configuration

5.6 DC/DC Converter

The Ag5500's DC/DC converter provides a regulated low ripple and low noise output that has built-in output over-load and short-circuit protection.

5.7 Output Configuration

The Ag5500 has two outputs which must be connected in parallel to provide 12V or in series to provide 24V, as shown in Figure 6: Output Configurations.

Output 2 voltage (VOUT 2) tracks the output 1 voltage (VOUT 1). The use of the two outputs separately is not recommended due to voltage regulation issues.

It is important that C1 and C2 are both used and connected as close to the output pins of the Ag5500 as possible (for both configurations). It is also important that C3 (100nF) is connected between VOUT 2 to 0V 1 (close to the pins) to reduce the level of output ripple and noise.

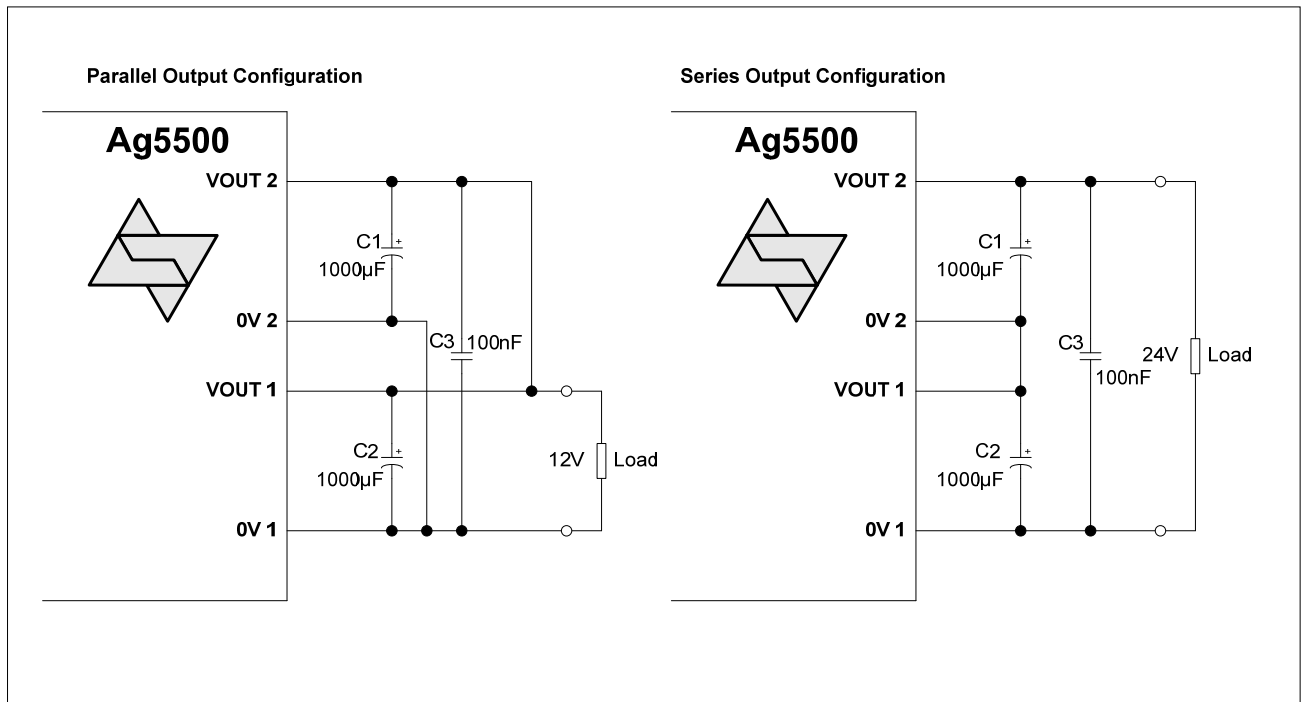

Figure 6: Output Configurations

It is also important that 0V 1 is connected to the system 0V (GND).

5.8 Output Adjustment

The Ag5500 has an ADJ pin, which allows the output voltage to be increased or decreased from its nominal value.

The adjustment range allows the Ag5500 to provide an output voltage from 10.55V up to 30.2V, contact Silvertel for further details.

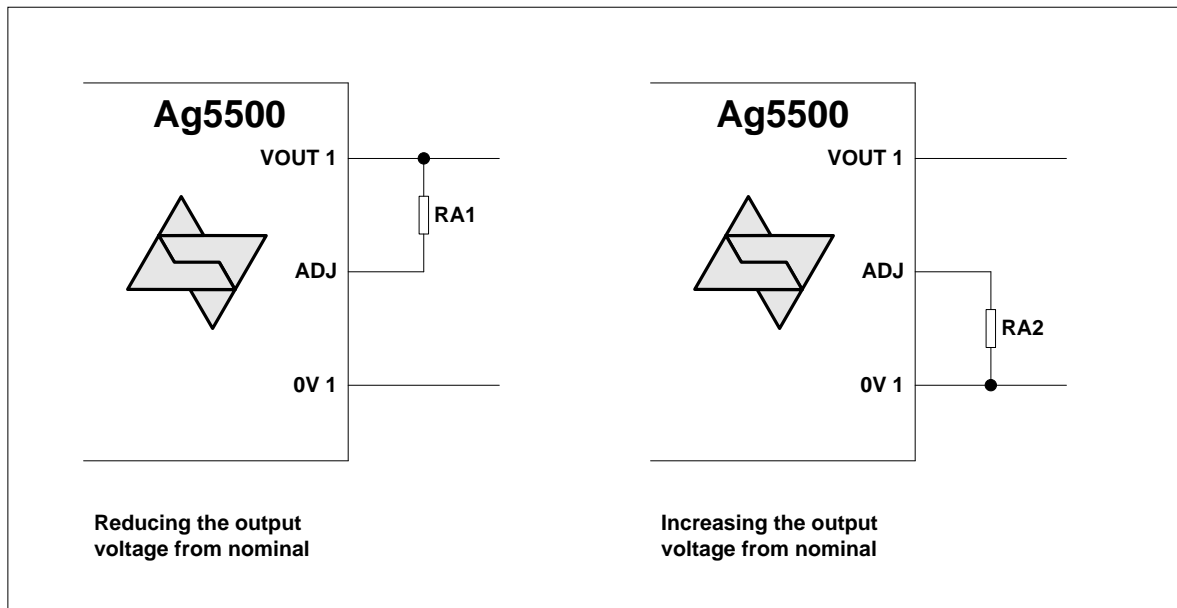

Figure 7: Output Adjustment

Reducing the output voltage, connect R between ADJ and VOUT 1		
Value of RA1	VOUT Parallel	VOUT Series
Open Circuit	12V	24V
91K	10.55V	21.1V
Increasing the output voltage, connect R between ADJ and 0V 1		
Value of RA2	VOUT Parallel	VOUT Series
Open Circuit	12V	24V
8K2	15V	30.2V

Table 3: Output Adjustment Resistor (R) Value

5.9 Output Power

The maximum output power of the Ag5500 is 60W; however this is limited by the available input power to the module.

When calculating the output power, the following factors must be taken into account: -

1. Ag5500 efficiency
2. PSE output power
3. Cable and connector losses
4. Input bridge rectifier losses

5.10 Typical Connections

As shown in Figure 8: Typical Connection Diagram, a minimum of $1000\mu\text{F}$ must be connected across each output, positioned as close to the output pins as possible. These capacitors are needed for output filtering and step load change performance and can be a standard low cost electrolytic; they do not need to be a low ESR type.

The Class programming and the Output Adjust inputs are optional and are provided to give greater flexibility to the Ag5500. Further information on using these inputs can be found in sections 5.4 Power Classification and 5.8 Output Adjustment.

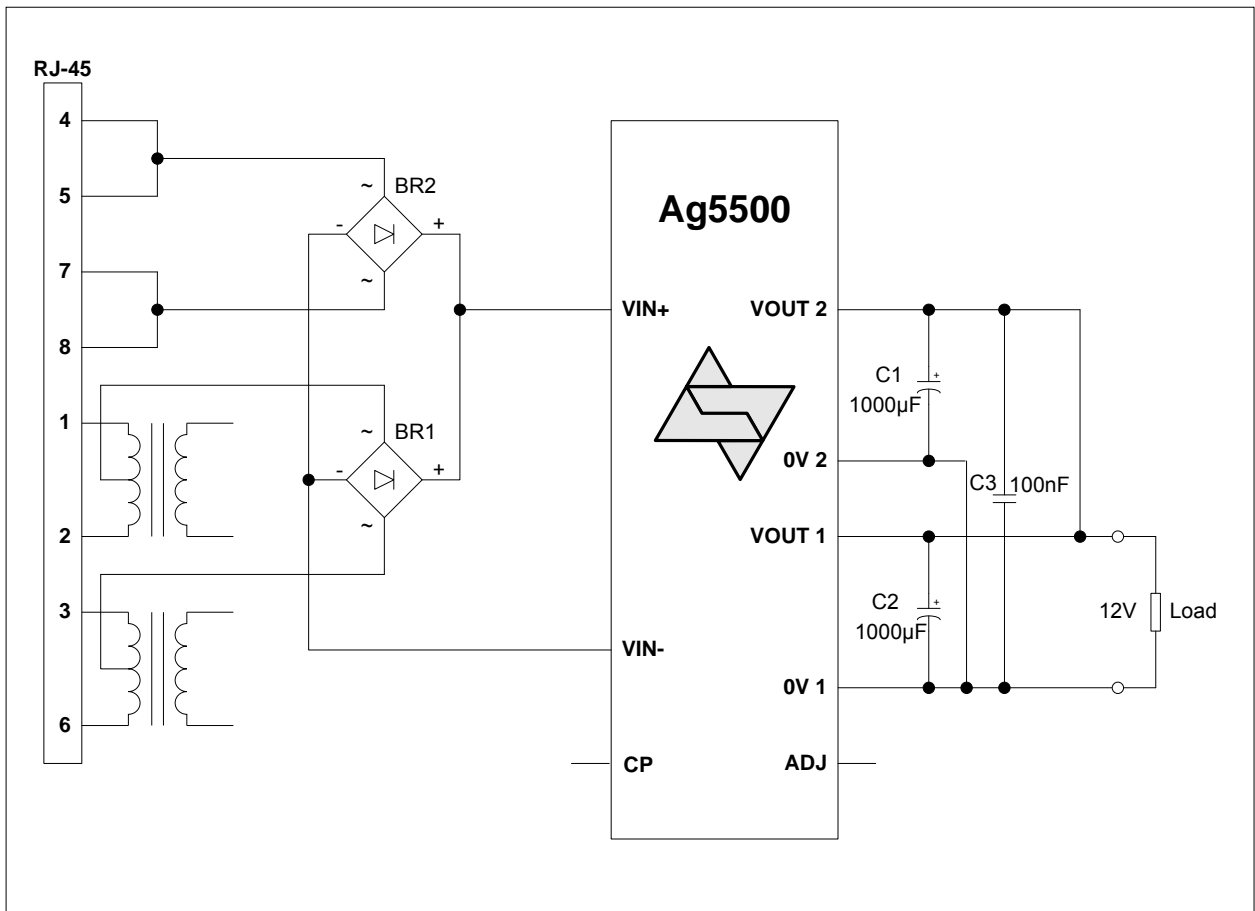

Figure 8: Typical Connection Diagram

6. Operating Temperature Range

It is important to remember that Ag5500 is a power supply, and as such careful consideration should be taken over the mechanical design of the host product, with provision for heat sinking and/or forced air cooling.

At full power the Ag5500 will generate heat. The device has been designed to be used with heatsink plate such as Aavid Thermalloy heat sink 241204B91200G, or thermally connected to the chassis of the host equipment, or cooled with forced air.

Below is a suggested mounting method for this type of heat sink.

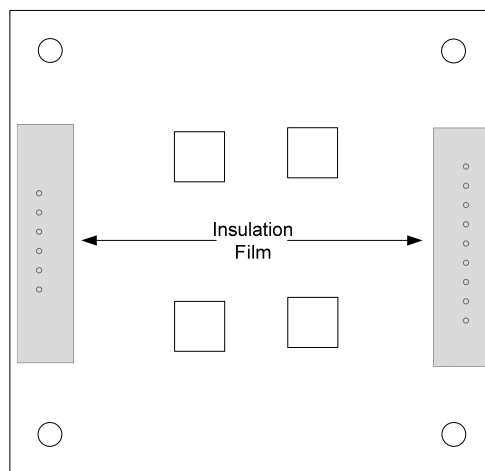

Figure 9: Module Pin Isolation (bottom view)

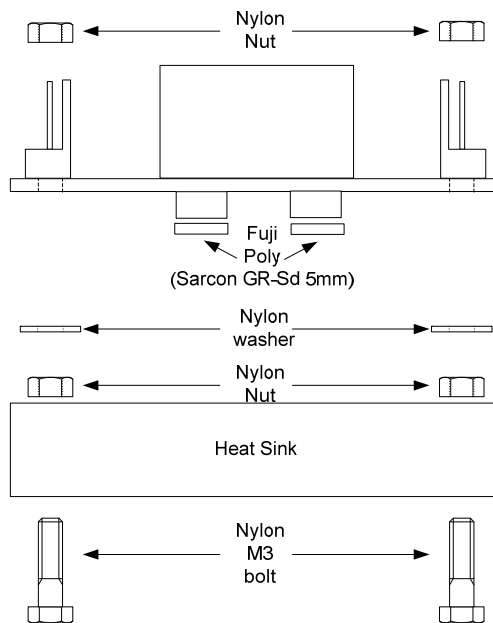

Figure 10: Suggested Heat Sink Assembly

7. Protection

The Ag5500 must be protected from over-voltages exceeding the 80V maximum rated surge input voltage. An inexpensive but effective solution can be achieved by connect Tranzorb diodes across each of the inputs; see Apps Note “ANX-POE-Protection”.

8. Connections

The input and output connectors are manufactured by Würth: -

Input 6 Way	–	Part No.	619 006 111 21
Output 9 Way	–	Part No.	619 009 111 21

Because of the high output current available and the need to keep the capacitors (C1 and C2 shown in Figure 6) as close to the output as possible. We recommend that any cable assembly be no longer than 150mm and the cable size be a minimum of: -

Conductor Area CSA: 0.5mm²
Conductor Make-up:16 / 0.2mm

9. Electrical Characteristics

9.1 Absolute Maximum Ratings¹

	Parameter	Symbol	Min	Max	Units
1	DC Supply Voltage	V _{CC}	-0.3	60	V
2	DC Supply Voltage Surge for 1ms	V _{SURGE}	-0.6	80	V
3	Storage Temperature	T _S	-40	+100	°C

Note 1: Exceeding the above ratings may cause permanent damage to the product. Functional operation under these conditions is not implied. Maximum ratings assume free airflow.

9.2 Recommended Operating Conditions

	Parameter	Symbol	Min	Typ	Max	Units
1	Input Supply Voltage @ 60W @ 20W	V _{IN}	52 36		57 57	V V
2	Under Voltage Lockout	V _{LOCK}	30		36	V
3	Operating Temperature ¹	T _{OP}	-20	25	70	Ta / °C

Note 1: See Section operating temperature range

9.3 DC Electrical Characteristics

	DC Characteristic	Sym	Min	Typ ¹	Max	Units	Test Comments
1	Nominal Output Voltage	+VDC	11.4 22.8	12 24	12.6 25.2	V V	Parallel O/P Series O/P
2	Voltage Adjust Range	V _{ADJ}	10.55		30.2	V	See Output Adjustment
3	Continuous Output Current ² (V _{IN} = Min 52V)	I _{CONT}			5.0 2.5	A A	Parallel O/P Series O/P
4	Line Regulation	V _{LINE}		0.1		%	@ 20W Load
5	Load Regulation	V _{LOAD}		0.15		%	@ V _{IN} =52V
6	Output Ripple and Noise Parallel O/P Series O/P	V _{RN}		70 110		mVp-p mVp-p	@ Max load ³
7	Minimum Load	R _{LOAD}	100			mA	
8	Short-Circuit Duration	T _{SC}			∞	sec	
9	Efficiency	EFF		87		%	V _{in} = 52V 50% Load
10	Isolation Voltage (I/O)	V _{ISO}			1500	V _{PK}	Impulse Test

Note 1: Typical figures are at 25°C with a nominal 56V supply, parallel output configuration (unless otherwise stated) and are for design aid only. Not Guaranteed

2: The output must not exceed 60W or 5.0A Parallel / 2.5A Series.

3: The output ripple and noise can be reduced with an external filter, see application note.

10. Package

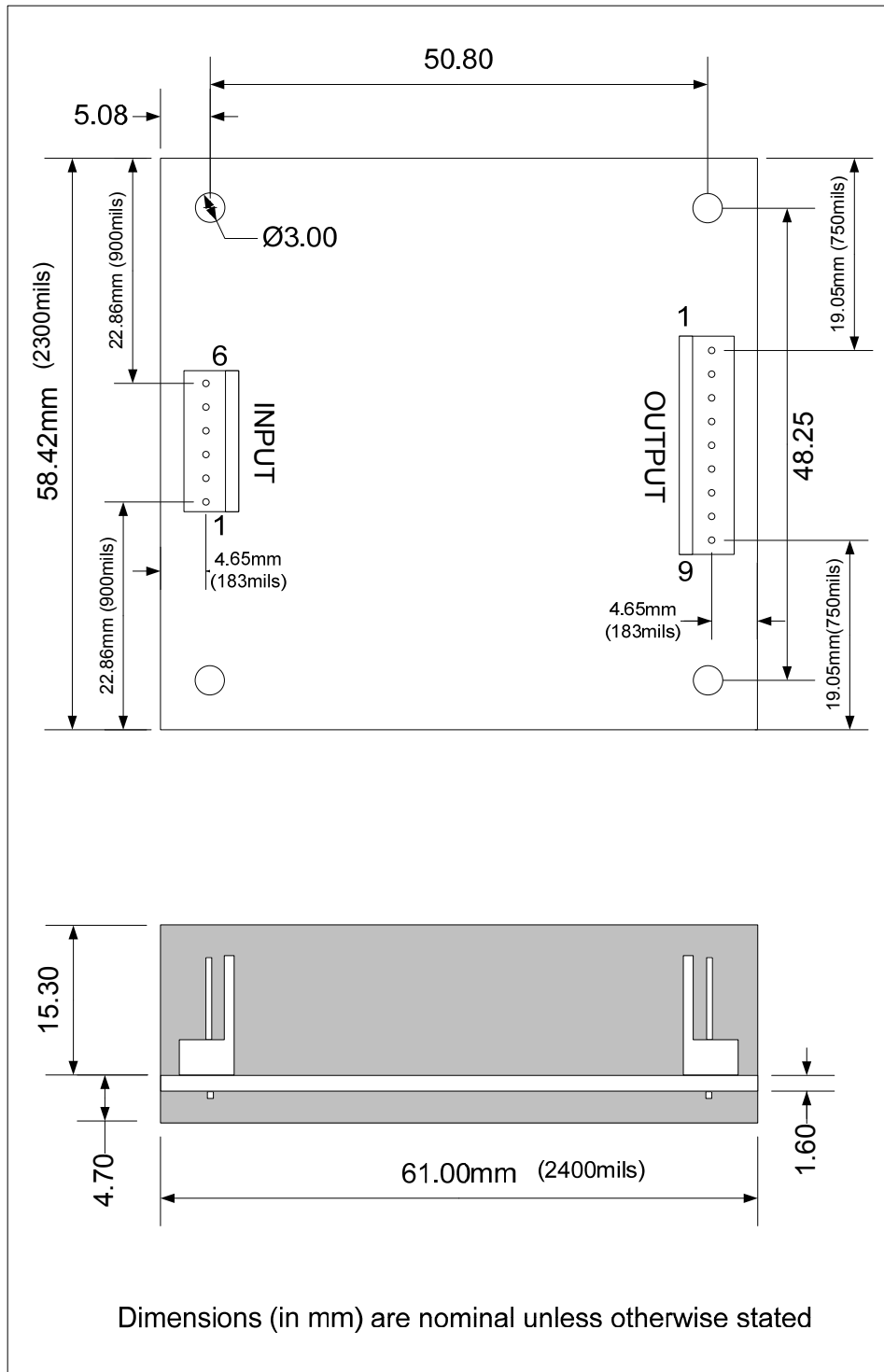

Information published in this datasheet is believed to be correct and accurate. Silver Telecom assumes no liability for errors which may occur or for liability otherwise arising out of use of this information or infringement of patents which may occur as a result of such use. No license is granted by this document under patents owned by Silver Telecom or licensed from third parties by Silver Telecom. The products, their specification and information appearing in this document are subject to change by Silver Telecom without notice.